

NOTES

Timber to be good quality redwood, pressure treated for external use in accordance with relevant British Standards. Treatment to be to Hazard Class 4. Any cuts or drilled holes on site to be retreated with timber preservative.

Timber to be smooth sawn finish.

All fixings to be non ferrous

Colour of stain to be Sadolin Classic 'Teak' or other similar approved.

Before filling with soil, landscape fabric to be tacked to line inside of planter.

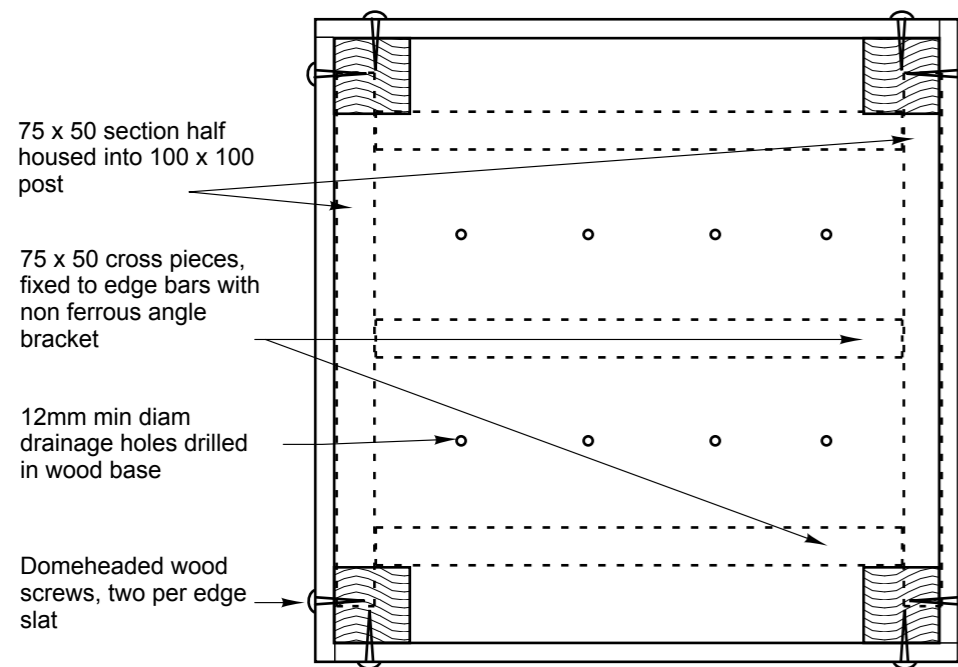

Photo showing finished appearance of planter, except that there should be **two** domed screws per horizontal edge board rather than only one.

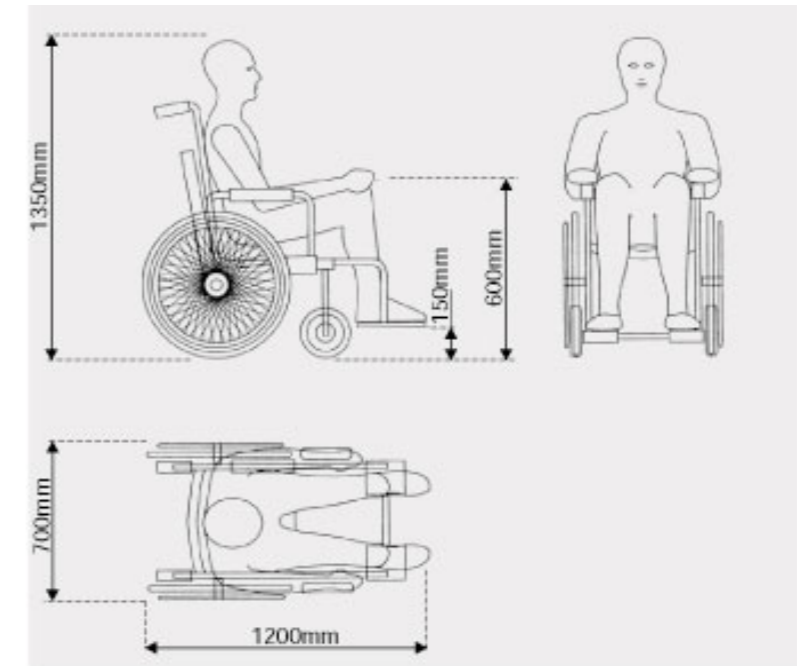

Diagram Wheelchair dimension - reference wheelchair

ArTerre Landscape Architect 17b Graham Street Edinburgh EH6 5QN Tel: 0131 555 3338 Fax: 0131 555 4446 e-mail: annie@arterre.co.uk	Project and client			
	Drawing			
Moveable Timber Planter for external use				
Dwg no	Rev	Scale	Date	
		1:10	08-01-07	